

A Self-Contained, Flow-Powered Microgenerator System

D. P. Arnold^{1*}, P. Galle¹, F. Herrault¹, S. Das², J. H. Lang², and M. G. Allen¹

¹School of Electrical and Computer Engineering, Georgia Institute of Technology, Atlanta, GA, 30332, USA

Phone: (404) 894-9419, Fax: (404) 894-5028, Email: mark.allen@ece.gatech.edu

²Dept. of Electrical Eng. and Computer Science, Massachusetts Institute of Technology, Cambridge, MA, 01239, USA

*now with Dept. of Electrical and Computer Engineering, University of Florida, Gainesville, FL, 32611, USA

Abstract

This paper reports the development of a fully functional, self-contained microgenerator system, which can power various portable electronics using only compressed gas. The system incorporates a previously reported axial-flux, permanent-magnet micromachine, an off-the-shelf air-turbine assembly, and self-powered electronics into a compact, standalone device. The purpose is to demonstrate the migration of a MEMS-based microgenerator from a bench-top laboratory experiment to a self-contained prototype for practical applications.

Keywords: magnetic generator, fluidic power, portable power source, permanent magnet machine

1 INTRODUCTION

Production of electrical power from a pressurized gas flow in an ultra-compact form factor presents a unique set of challenges. Such electric power sources must be efficient, rugged, and capable of relatively high power output, over 1 W. One potential solution for electromechanical energy conversion is a permanent-magnet (PM) generator [1]. PM generator technology is attractive because it offers simple operation and construction, a prerequisite for feasible miniaturization, and harnesses the superlative magnetic properties of PM materials. These PM generators have been developed to a level of robustness that they can readily be integrated into more complex systems.

Once ultracompact PM generators have been demonstrated, the next system development step is the construction of a *stand-alone* generator. A stand-alone mechanical-to-electrical power generation system consists of (1) means for converting mechanical power to rotary motion; (2) a PM generator; and (3) compactly-packaged electronics for output power conversion and regulation. The purpose of this paper is to present one solution to a stand-alone generation system, namely a system powered by compressed gas and generating electrical power.

Although compressed gas is an inferior energy density source when compared to standard batteries, such a device may find use in a larger system where compressed gas streams are available and it is impractical to run extensive electrical wiring. One example would be powering of wireless sensor networks in industrial processing plants.

2 SYSTEM DESIGN

An axial-flux, planar PM generator is combined with an off-the-shelf air-turbine and power electronics to form a self-contained microgenerator system. The system uses compressed gas to spin a magnetic generator to provide output electrical energy. It is built in a modular fashion and comprises three major components: (1) the air-turbine assembly, (2) the magnetic generator, and (3) the power

electronics. The complete system measures 3.8 cm on a side, with a volume of 55 cm³, as shown in Fig. 1.

2.1 Mechanical

The air-turbine assembly is a stainless steel block that houses the air-turbine. Manufactured for use in a dental drill, the air-turbine supports rotational speeds of up to 400 krpm and is designed to interface to a 1.6 mm shaft. The turbine consists of an impeller and a spindle chuck supported by high-speed ball-bearings, as shown in Fig. 2.

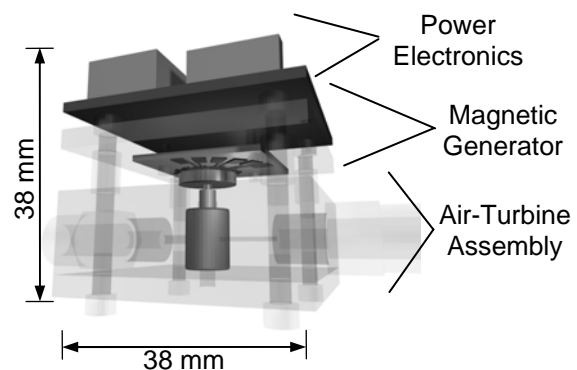

Figure 1. Standalone power generation system schematic

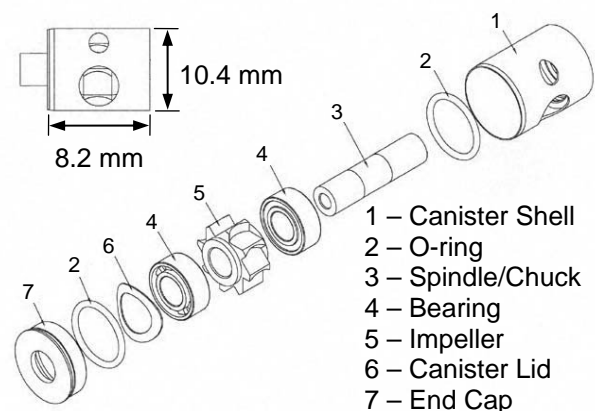

Figure 2. Exploded view of off-the-shelf dental drill air-turbine [excerpted from www.handpieceparts.com]

The assembly block was conventionally machined and incorporates a center bore to accommodate the turbine assembly. Inlet and outlet ports permit fluidic connection to the turbine via standard tubing connectors. A steel plate fastened to the bottom of the assembly secures the air-turbine in place, and access to the turbine chuck is provided through a hole on the top of the block. A second steel plate, the backplate, is attached to the top of the steel block via spacer supports. The generator stator and power electronics are attached to the bottom and top faces, respectively, of this plate, and the spacers determine the air gap between the generator rotor and stator. The entire assembly is shown in Fig. 3.

2.2 Magnetic

The magnetic generator comprises a previously reported, 8-pole, 2-turn/pole stator and a rotor using a 1 mm-thick SmCo permanent-magnet with a 0.5 mm-thick FeCoV back iron supported in a titanium housing [1,2]. The rotor components are mounted on a steel shaft, which fit into the air-turbine. The rotor-stator air gap is set to $\sim 200 \mu\text{m}$ by the spacers. Three-phase output leads are soldered to the stator bond pads and routed to the power electronics board.

2.3 Electrical

The power electronics convert the three-phase sinusoidal machine waveforms to a constant 5 Volt DC output, as

shown in Fig. 4. Three custom-wound transformers step up the voltage for rectification through a three-phase Schottky diode bridge. The rectified voltages are passed through a 5 V voltage-regulator to provide a constant output voltage under varying load conditions.

3 SYSTEM CHARACTERIZATION

3.1 Compressed Gas Source

The system can be powered by a variety of pressure-regulated compressed gas sources (e.g. nitrogen, compressed air, CO_2 , etc.). Precise measurements of the volumetric flow rate have not been made, but estimates are on the order of 25 to 45 L/min. For portable applications, a 500 g liquid CO_2 tank was found to provide 10-15 minutes of continuous power, depending on the electrical load. Additionally, using a constant source of nitrogen, the system has been run for up to an hour continuously with no failures.

3.2 Experimental Setup

The configuration shown in Fig. 5 was used to characterize the system. Compressed nitrogen (N_2) was used as the gas for all testing, and pressure gauge located at the device inlet was used to monitor the inlet pressure. Two digital multimeters were used to simultaneously measure the DC current and voltage delivered to the load. A frequency

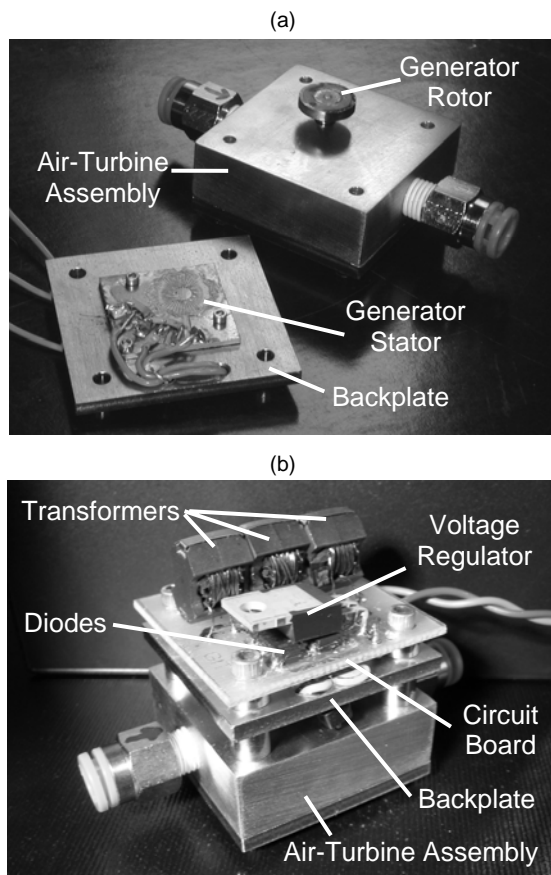

Figure 3. Standalone power generation system (a) before and (b) after assembly.

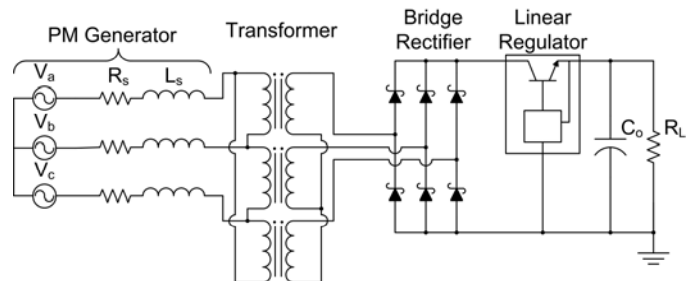

Figure 4. Circuit schematic of power electronics: three-phase voltage rectification and regulation.

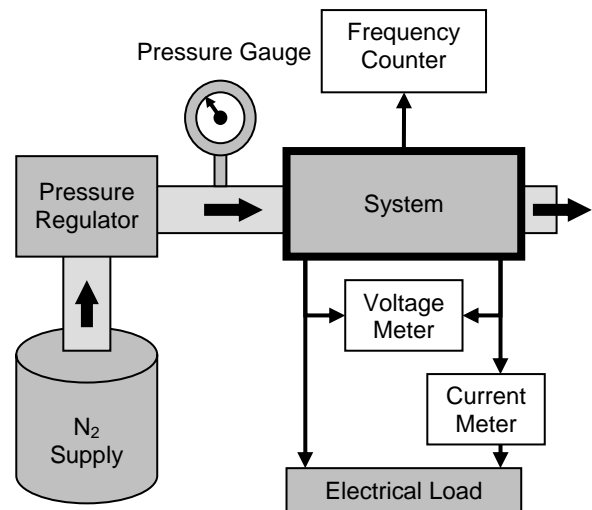

Figure 5. Experimental characterization setup. Heavy arrows indicate compressed gas flow

counter monitored the generator (sinusoidal) waveforms, and was used to measure the generator's rotational speed.

Measurements were taken with inlet pressure, airflow, and generator speed all constant. For this system characterization, the voltage regulator was bypassed, and the electrical load was an adjustable resistive load. For each measurement point, the inlet pressure, load current, and load voltage were measured.

3.3 Open-Circuit Voltage

Fig. 6 shows the system's inlet pressure and output DC voltage as a function of speed with no load attached. The voltage data agree with the expectation that open circuit voltage should increase linearly with the rotation rate [1]. There is also an apparent proportional relationship between inlet pressure and output voltage, under no-load conditions.

3.4 Power Output

Fig. 7 shows the inlet pressure and DC power output at various speeds, as the load resistance is varied. As expected, at all speeds the maximum power was delivered when the load was equal to the system's internal impedance, approximately 50 Ω. A maximum power output of 1.11 W was achieved at 200 krpm into a matched load. This required 87 kPa at the generator inlet and an estimated flow rate of approximately 45 L/min.

3.5 Powering of Electronic Devices

In addition to this systematic characterization, three electrical devices were connected as loads to the system (via the 5 V voltage regulator) – an ultrabright LED array, a Palm IIIe PDA, and a cordless phone handset. Powering such devices demonstrates the applicability of this system for “real-world” applications. Shown in Table 1 are the associated measurements. These numbers represent sustained loads during periods of device activity, such as booting for the PDA or carrying an audio signal for the phone handset.

Table 1. Powering of common electronic devices.

Device	Inlet Pressure [kPa]	Generator Speed [krpm]	Delivered Power [mW]
PDA	51	125	200
LED array	25-50	60-100	80-280
Cordless phone handset	65	150	360

4 CONCLUSION

These results validate the use of a MEMS-based PM generator to supply “real-world” power to portable electronic devices. The generator power density is 10 W/cm³ (0.1 cm³). However, when the entire volume of the system is considered, the power density is only 0.02 W/cm³ (55 cm³). This indicates the need for further miniaturization of the power electronics and mechanical components, particularly in the turbine assembly. Also, increasing the power output capacity, both by refinement of

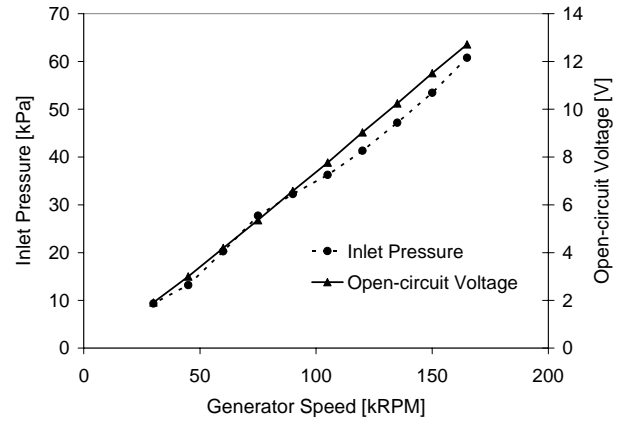

Figure 6. System inlet pressure and open-circuit output voltage as a function of speed.

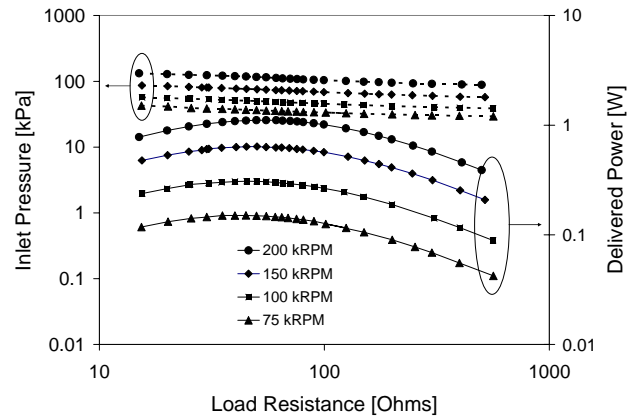

Figure 7. System inlet pressure and DC output power vs. load resistance at various generator speeds

the PM generator components as well as use of higher-power air-turbines, are possible avenues for future improvement.

While the required inlet pressures can be easily achieved using portable compressed gas sources (ex. disposable CO₂ cartridges), the relatively large inlet flow rates make this system better suited for environments where continuous fluid flow is readily available.

5 ACKNOWLEDGMENTS

This work was supported by the United States Army Research Laboratory Collaborative Technology Alliance (DAAD19-01-2-0010).

REFERENCES

- [1] S. Das, et al., “Multi-watt electric power from a microfabricated permanent-magnet generator,” *MEMS 2005*, pp. 287-290.
- [2] D. P. Arnold, et al., “High-speed characterization and mechanical modeling of microscale, axial-flux, permanent-magnet generators” *Transducer's 05*, pp. 701-704.